

Multinational Study on the production of microalgae for human nutrition

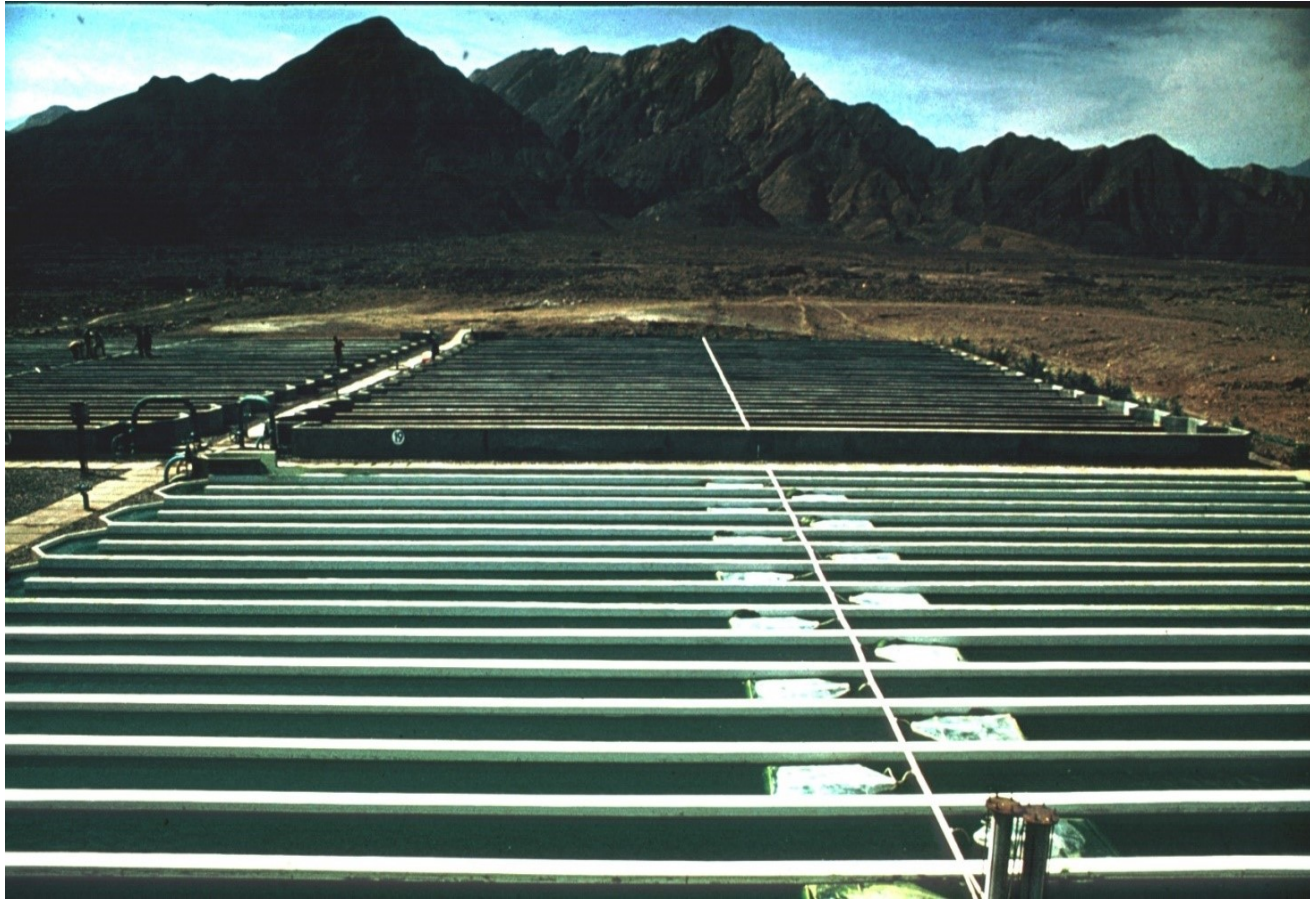

Algae production (*Scenedesmus*) in Peru, Trujillo 8° South, Type Open Pond (raceway), 1972
Similar plants were operated the same time in Israel, Egypt and Thailand

Experimentelle Untersuchung und Vermessen des Blitzlichteffekts bei Kulturen von Mikroalgen

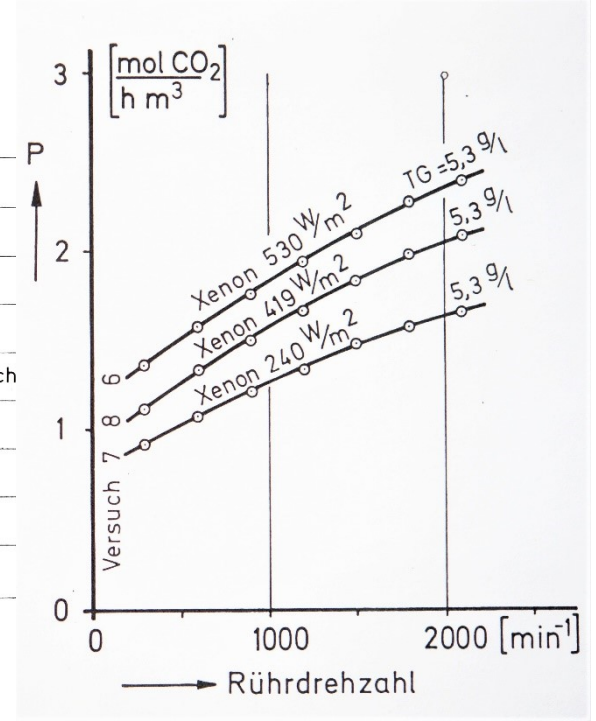
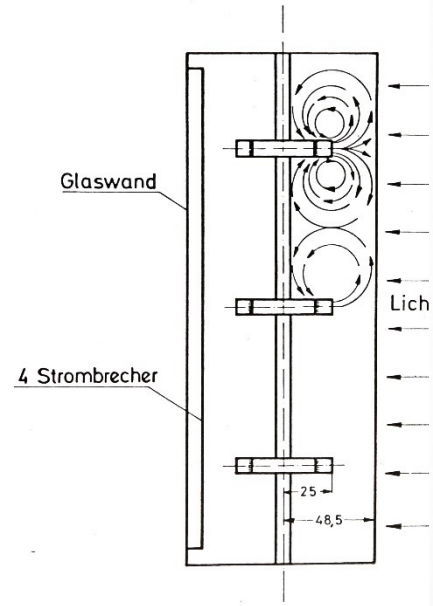
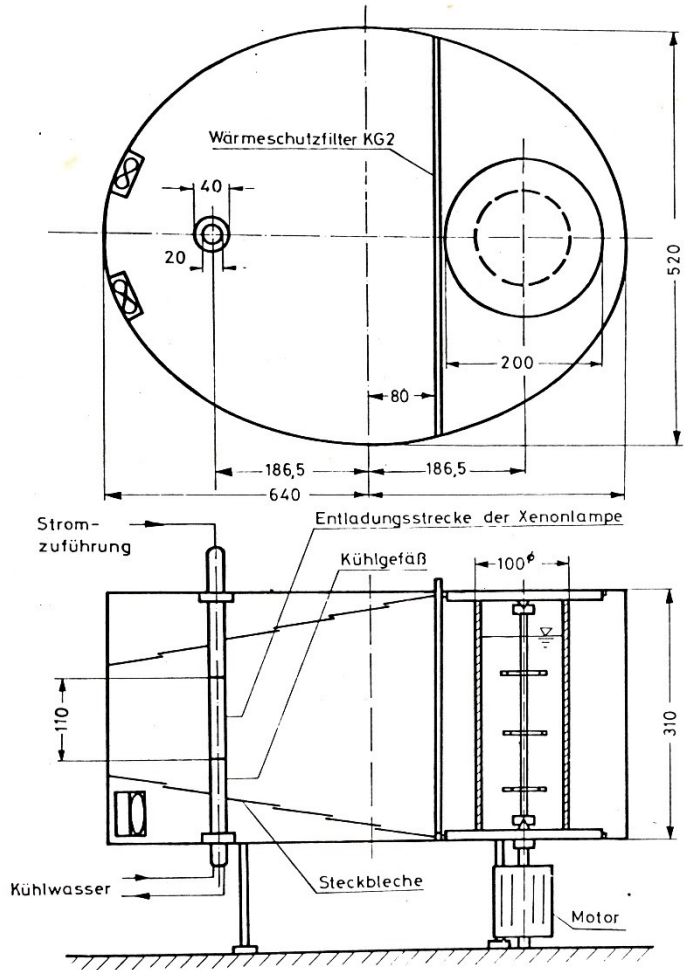

Das Licht der Xenonlampe wird mit Hilfe eines Wärmeschutzfilters dem Spektrum von Sonnenlicht angepasst.

Die am Reaktor auftreffende Intensität variiert von dem des Sonnenlichts bis zum Doppelten derselben.

Die durch den Rührer hervorgerufene Strömung bewirkt, dass die einzelne Alge einem intermittierenden Licht ausgesetzt wird. Auf diese Weise können auch sehr dichte Algenkulturen ausreichend mit Licht versorgt werden. Auch bei ungewöhnlich hohen Lichtintensitäten wird ein Ausbleichen der Kultur zuverlässig vermieden. Mit zunehmender Rührerdrehzahl erhöht sich die Photosyntheseleistung P der Kultur (Blitzlichteffekt).

Foil Reactors. Safe and in situ autoclavable. No Glas.
National and international Patents.

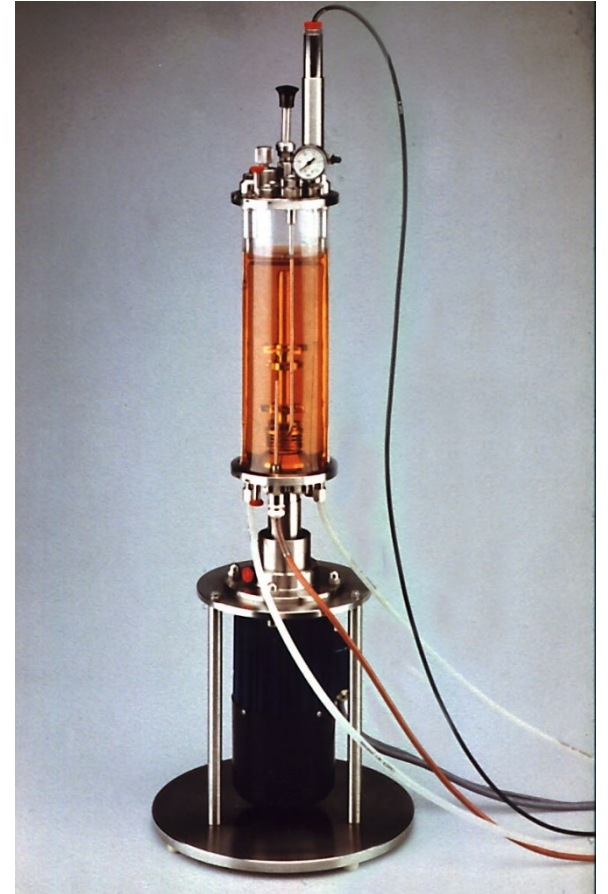
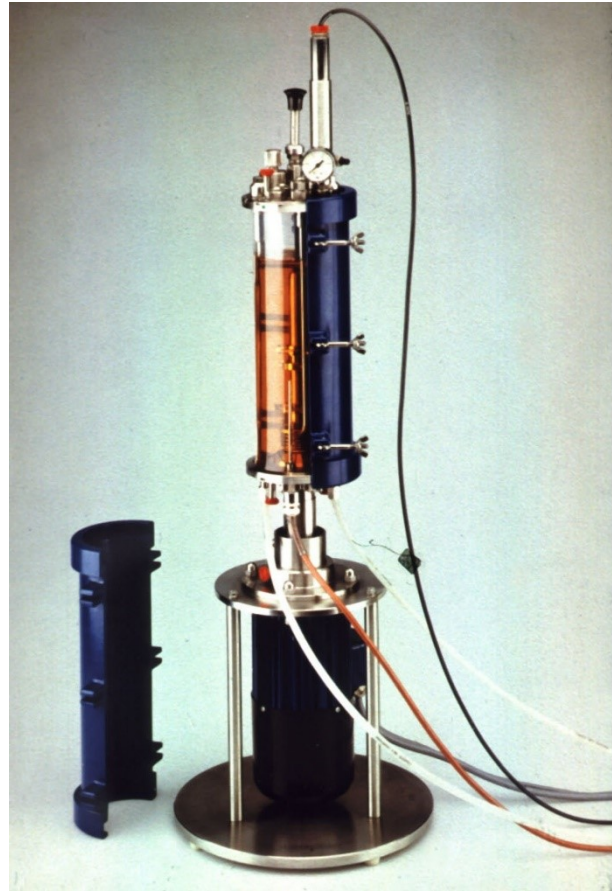
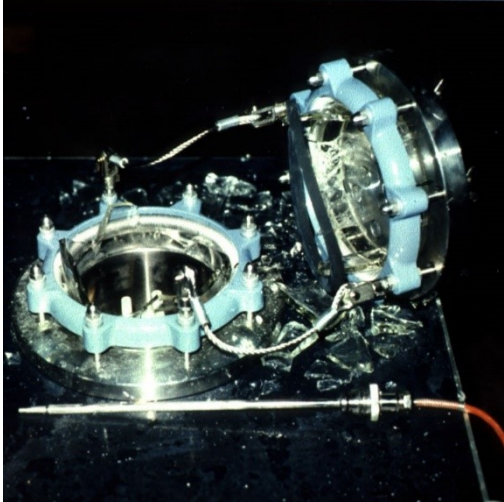

produced by Bioengineering CH
Wald

Development of save laboratory reactors for the production of algae



In use:
European Space Agency, Barcelona.
Universität Bochum.
Reactors produced by Bioengineering CH Wald

Membrane Reactor



produced by
Bioengineering
CH Wald

Used by: Yonsei University Seoul, Karolinska Institutet Stockholm, University Gent Laboratory for Microbial Ecology, Institut für Lebensmitteltechnologie Berlin, Onderstepoort Biological Products Johannesburg for the production of botulinum toxin for medical use.
National and international Patents

Dialysis Membrane Bioreactor

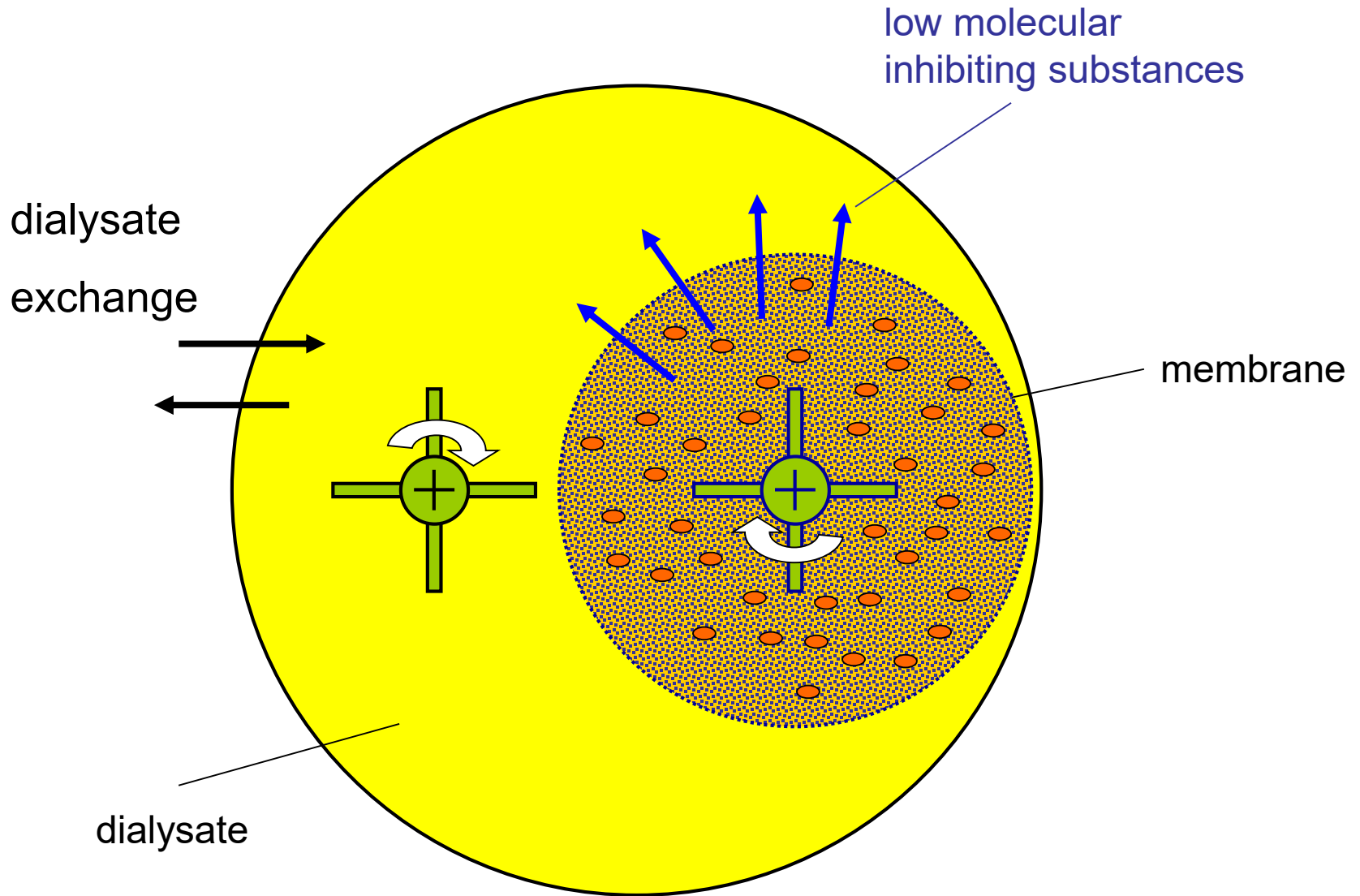

Theoretical maximum cell concentration *Escherichia coli* K12

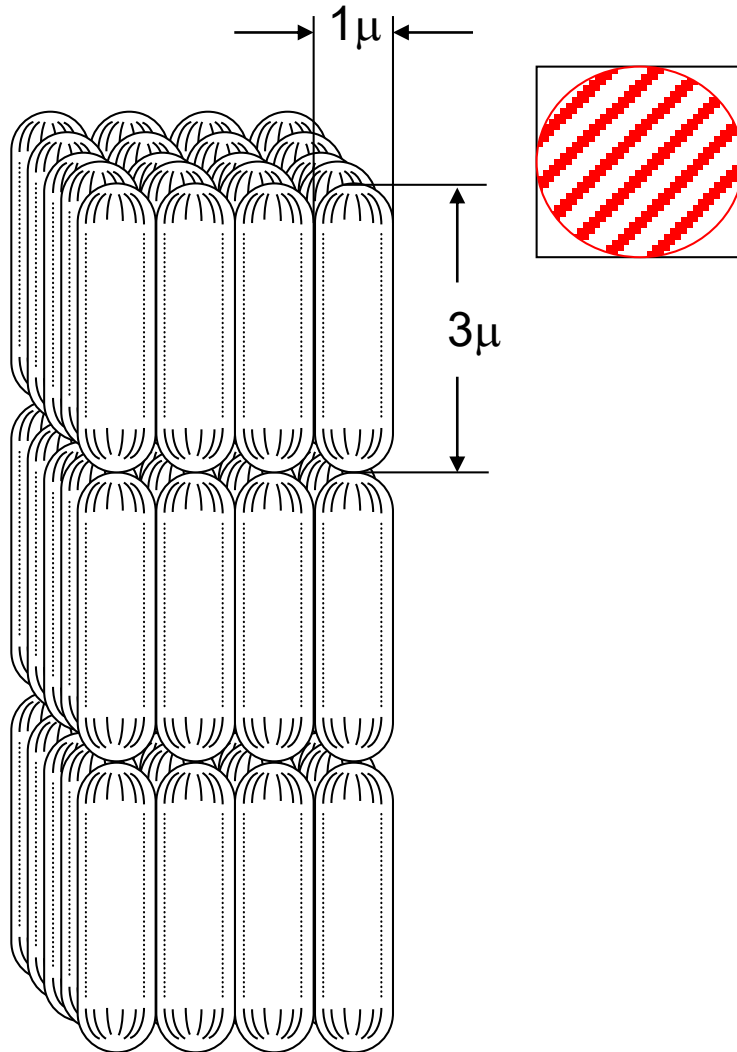

Void fraction $1 - \pi/4 = 0.21$
Total amount of culture broth 25%

Maximum cell mass in 1 liter
800 g (wet weight)
cell dry weight 25%

**Maximum cell concentration:
200 g / liter cell dry weight**

Dialysis cultivation of *Escherichia coli* K12

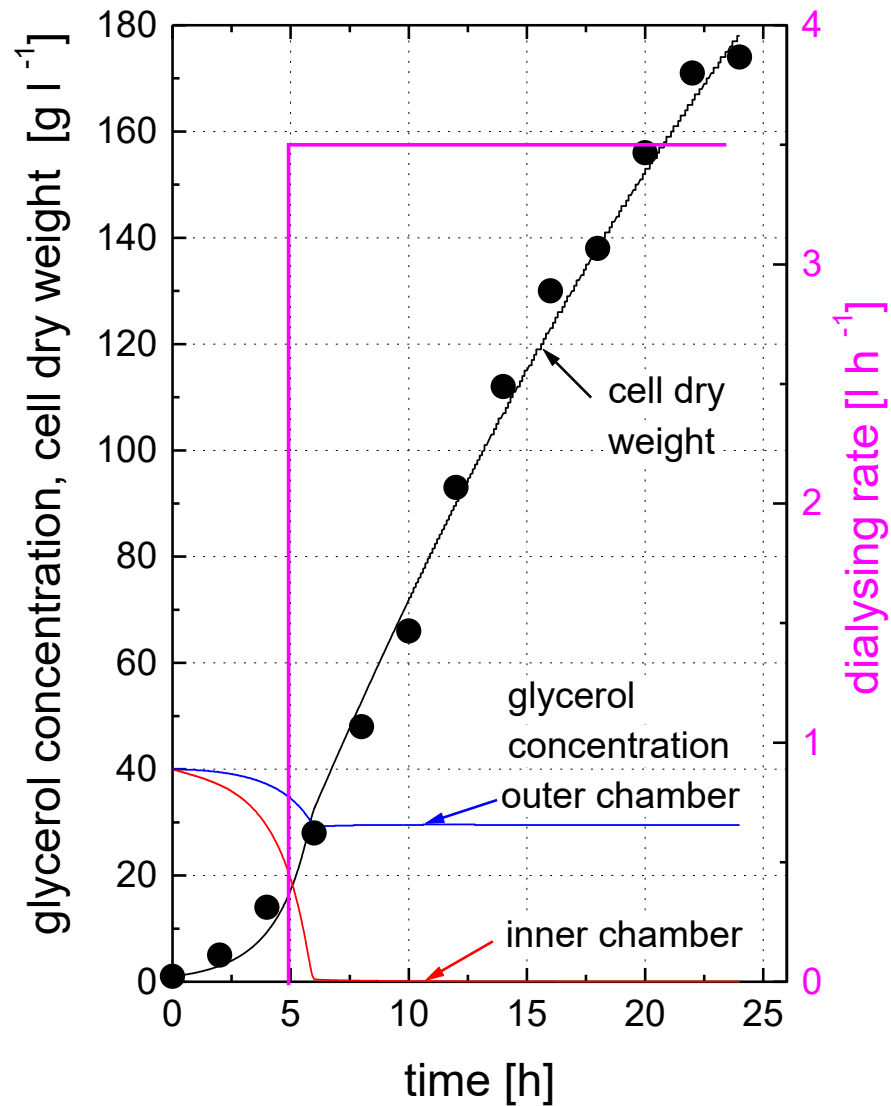

Fermentation of *Pyrococcus furiosus*, anaerobic hyperthermophilic

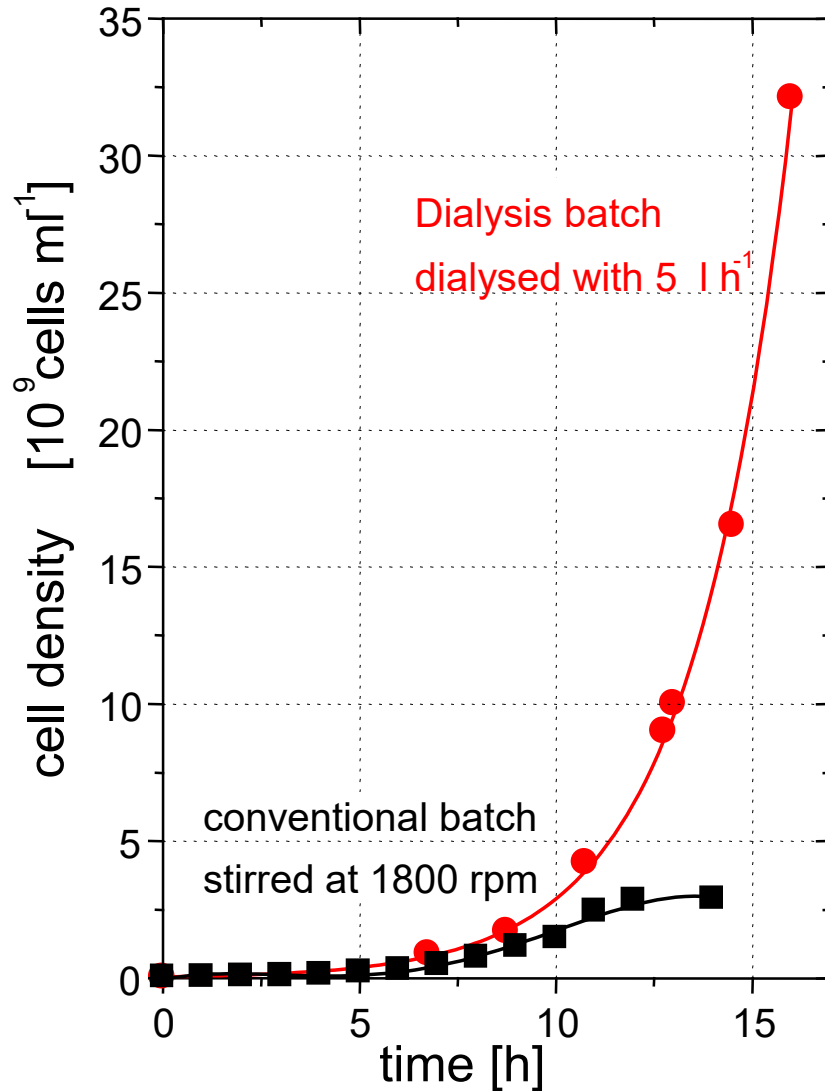

T = 90°C

pH = 6.4

aeration with CO₂ and N₂

2.6 g/l dry weight reached
in the dialysis fermentation
compared to 0.03 g/l in a vial

Cooperation
Garo Antranikian

Fermentation of *Sulfolobus shibatae* aerobic hyperthermophilic and acidophilic archaeon

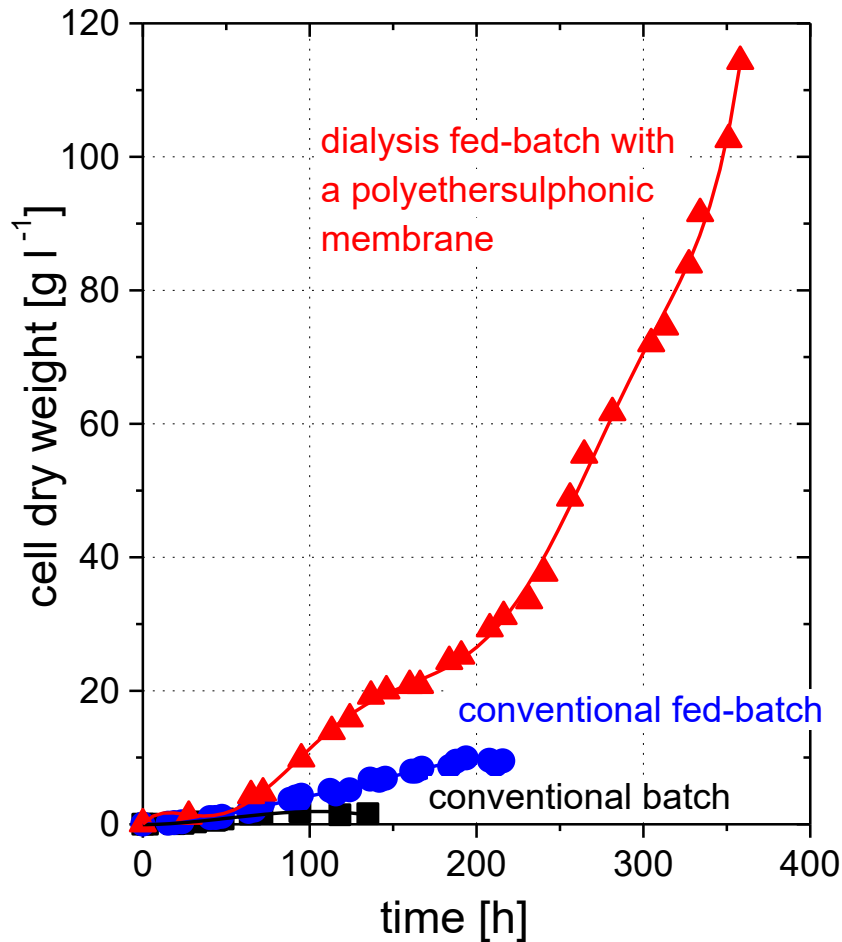

T = 75 °C
pH = 3.5
aeration with air

conventional fed-batch
fermentation: 10 g/l cdw
dialysis fed-batch fermentation:
114 g/l cdw

Coop.:
R. Ladenstein
Mario de Rosa

Fermentation of genetically modified microorganisms, semi Industrial scale



Biogas Tower Reactor, Pilot Plant



Technical Data

Height: 22 m

Diameter: 1 m

Volume: 15 m³

Pilot Experiments on the Campus of
Hamburger Hefewerke, Hamburg-Wandsbek

Tower Type Biogas Reactor using
wastewater out of yeast production.
National and international Patents



Biomar[®] AHP Reactor

reactor height: 22 m

diameter: 3,6 m

Volume: 2 x 200 m³

Uses Wastewater from biodiesel
production: Glycerol, Methanol,
fat / oil

Production of Biogas

Constructed by Enviro Chemie, Rossdorf.

Another 5 Reactors of this Type are in use in food
and drink industry